

RACKS BRAX.®

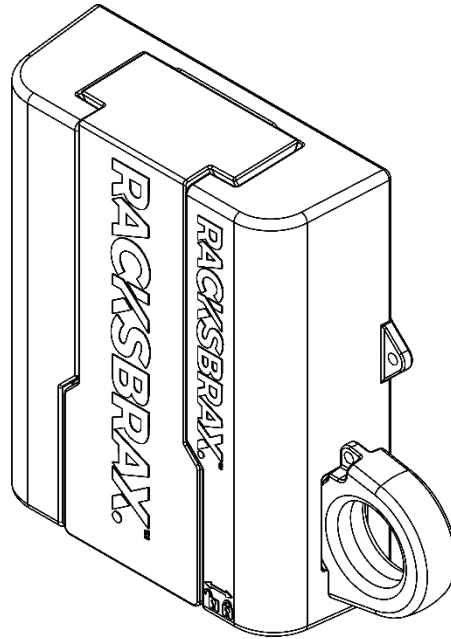

HD HITCH

Assembly and Mounting Instructions

HD Hitch Standard (8159, 8179*)
HD Hitch Tradesman II (8162, 8180*)
HD Hitch Tradesman III (8163, 8181*)
HD Hitch Triple (8182, 8183*)

The RacksBrax HD Hitch has been engineered to ensure safety, quality and ease of use for the quick loading and unloading of roof rack mounted pull-out awnings*, storage tubes and shower tents. When coupled with various RacksBrax HD Accessories (sold separately), the HD Hitch may also be used with some wing awnings**, some recovery boards*** and some soundbars****. See website for more detail.

**These models suit SUPA PEG awnings and may be used for only those SUPA PEG wing awnings with awning spine mount points at 33mm centres.*

*** Not to be used for wing awnings with mount point spacings from 40 and 52mm. See XD Hitch and XD Hitch Accessories at www.racksbrax.com.*

**** Full-sized MAXTRAX® and TRED® recovery boards.*

***** ECOXGEAR® soundbars.*

Page intentionally left blank.

Table 1 CONTENTS BY PRODUCT

PART	QUANTITIES SUPPLIED IN EACH BOX							
	HD Hitch Standard 8159	HD Hitch Standard (SUPA PEG MODEL) 8179	HD Hitch Tradesman II 8162	HD Hitch Tradesman II (SUPA PEG MODEL) 8180	HD Hitch Tradesman III 8163	HD Hitch Tradesman III (SUPA PEG MODEL) 8181	HD Hitch (TRIPLE) 8182	HD Hitch (TRIPLE) (SUPA PEG MODEL) 8183
Body (with lock)	2	2	4	4	5	5	3	3
Body (Wall Mount - no lock)	/	/	2	2	2	2	/	/
Holder	2	2	4	4	6	6	3	3
Cover	2	2	2	2	3	3	3	3
Pin	2	2	2	2	3	3	3	3
Prop Cleat	2	2	2	2	2	2	2	2
Barrel Lock	2	2	2	2	3	3	3	3
Pin Lanyard	2	2	2	2	3	3	3	3
Fastener Set 8159	1	/	1	/	1	/	1	/
Fastener Set 8179	/	1	/	1	/	1	/	1
Fastener Set 8162	/	/	1	/	/	/	/	/
Fastener Set 8180	/	/	/	1	/	/	/	/
Fastener Set 8163	/	/	/	/	1	/	/	/
Fastener Set 8181	/	/	/	/	/	1	/	/
Fastener Set 8182	/	/	/	/	/	/	1	/
Fastener Set 8183	/	/	/	/	/	/	/	1
Instructions	1	1	1	1	1	1	1	1
Warranty and Safety Warnings	1	1	1	1	1	1	1	1

Table 2 QUANTITIES IN EACH BOX
(see Figure 1 – Exploded View over page)

#	PART	QUANTITIES							
		HD Hitch Standard 8159	HD Hitch Standard (SUPA PEG MODEL) 8179	HD Hitch Tradesman II 8162	HD Hitch Tradesman II (SUPA PEG MODEL) 8180	HD Hitch Tradesman III 8163	HD Hitch Tradesman III (SUPA PEG MODEL) 8181	HD Hitch (TRIPLE) 8182	HD Hitch (TRIPLE) (SUPA PEG MODEL) 8183
3	Body (with inbuilt lock not shown)	2	2	4	4	5	5	3	3
NOT SHOWN	Body (Wall Mount-no lock)	/	/	2	2	2	2	/	/
8	Holder	2	2	4	4	6	6	3	3
NOT SHOWN	Cover	2	2	2	2	3	3	3	3
4	Pin	2	2	2	2	3	3	3	3
NOT SHOWN	Prop Cleat	2	2	2	2	2	2	2	2
NOT SHOWN	Pin Lanyard	2	2	2	2	3	3	3	3
10	Generic Awning	/	/	/	/	/	/	/	/
6*, 9*	SS304 SET SCREW M6 X 20*	8	/	12	/	16	/	12	/
NOT SHOWN	SS304 SET SCREW M6 X 25* (for Prop Cleat)	2	/	2	/	4	/	2	/
2*, 5*	SS304 WASHER MUD M6 X 18MM*	10	/	14	/	22	/	14	/
1	SS304 NUT NYLOC M6*	10	/	14	/	20	/	14	/
9	SS304 SET SCREW M8 X 20***	4	4	8	8	12	12	6	6
6	SS304 SET SCREW M8 X 25	6	6	6	6	8	8	8	8
2	SS304 WASHER FLAT M8 X 17 X 1.2	6	6	6	6	8	8	8	8
5	SS304 WASHER MUD M8 X 22****	6	4	8	6	12	9	9	6
1	SS304 NUT NYLON INSERT M8	10	10	14	14	20	20	14	14
7	SS304 HOLDER WASHER M8 2mm X 32mm X 22.5mm*****	2	2	4	4	6	6	3	3
NOT SHOWN	SS304 T BOLT M8 25mm (OR 35mm) 20mm X 12.4mm X 4mm **	2	/	2	/	2	/	2	/
NOT SHOWN	SS304 WASHER M8 30mm X 14.5mm X 2mm*****	/	2	/	2	/	3	/	3

- * Used where only M6 set screw heads fit awning mounting slots
- ** Supplied for prop cleats for Rhino Rack® Sunseeker® awnings
- *** Use T Bolts supplied with Rhino Rack® Sunseeker® awnings to attach nylon Holders to Sunseeker® awnings
- **** Use these washers on the inside of nylon Body and upper inside of the nylon Holders
- ***** Used for Supa Peg Models only on the lower inside of the nylon Bodies
- ***** Use these washers on the lower inside of the nylon Holders.

RACKSBRAX.

Figure 1 EXPLODED VIEW

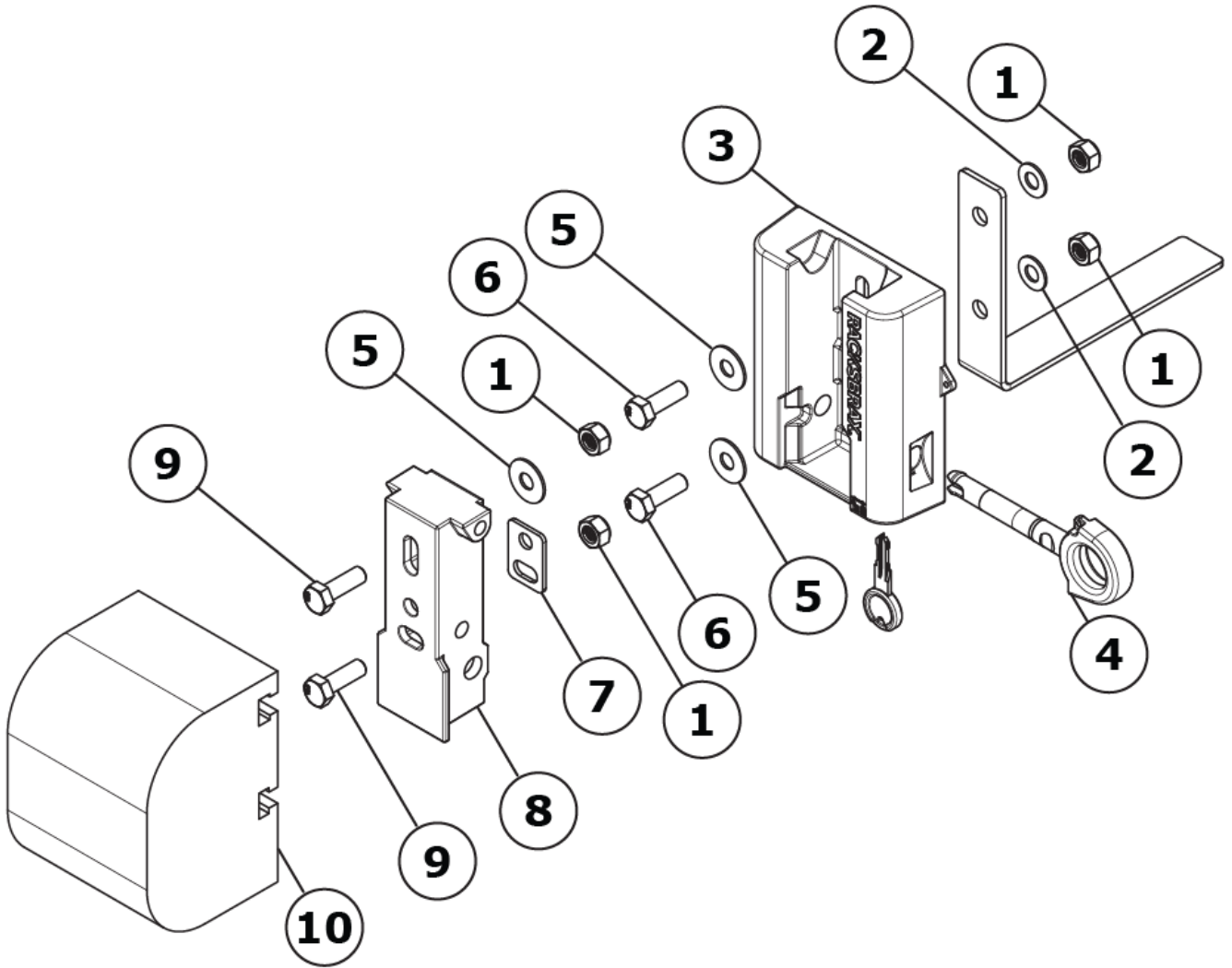

WARNING

(Read in conjunction with RacksBrax "SAFETY WARNINGS")

- 1) Set Screw torque settings:
M6 = 6Nm (4 ft.lb), M8 = 6Nm (5 ft.lb)
- 2) Do not use nylon-insert lock nuts more than once
- 3) **DO NOT USE DRILL TO TORQUE BOLTS.**
- 4) **Maximum load** per single HD Hitch/HD Awning Adaptor Plate pair is 20kg (44lb).
A lesser roof rack capacity may reduce this.
- 5) Pitched awnings connected to a RacksBrax HD Hitch, should be pitched in accordance with the manufacturer's instructions **but in any case, with guy ropes, or other awning restraint mechanisms designed to secure an awning during windy conditions.**
- 6) Wind damage is not covered under the Warranty.
- 7) Awnings must be restrained in windy conditions, drained during rain and cleared during snow.

RACKSBRAX.

Set screw configuration if a pull-out awning is to be used freestanding (see Pages 12 to 13). Or when used with a RacksBrax HD Awning Adaptor Plate.

1

Generic bracket shown.

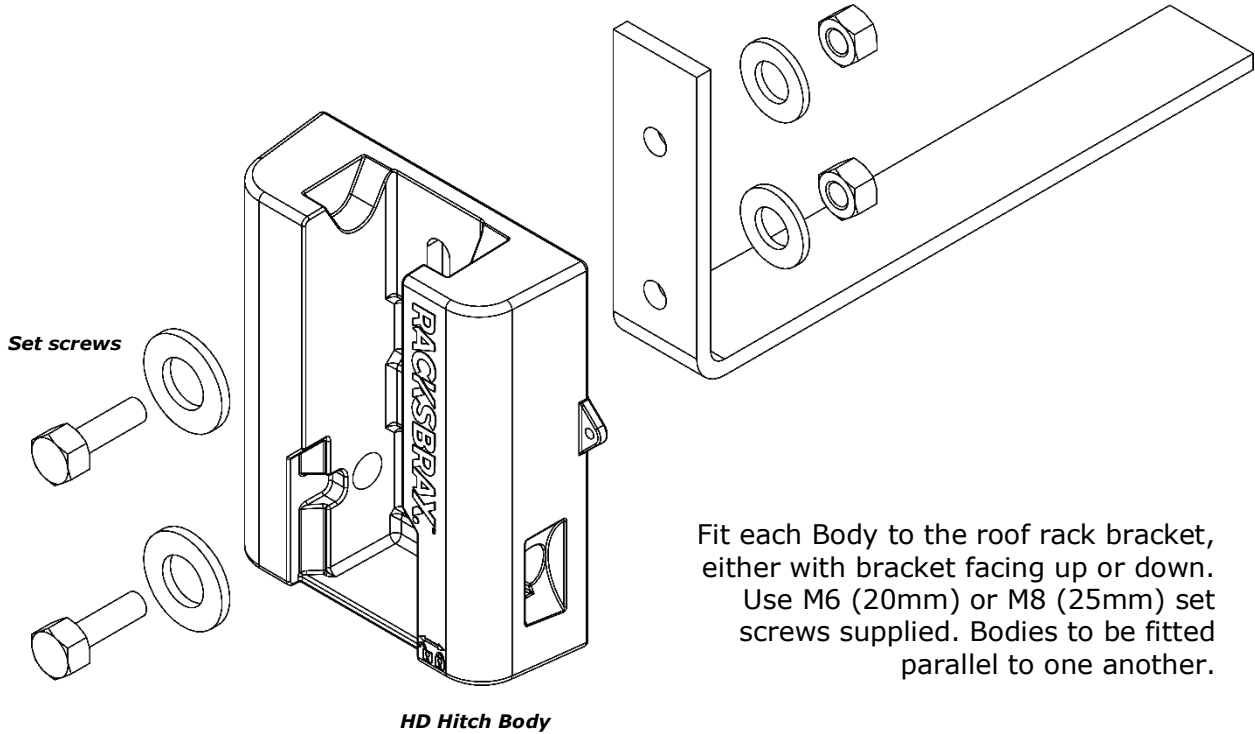

2

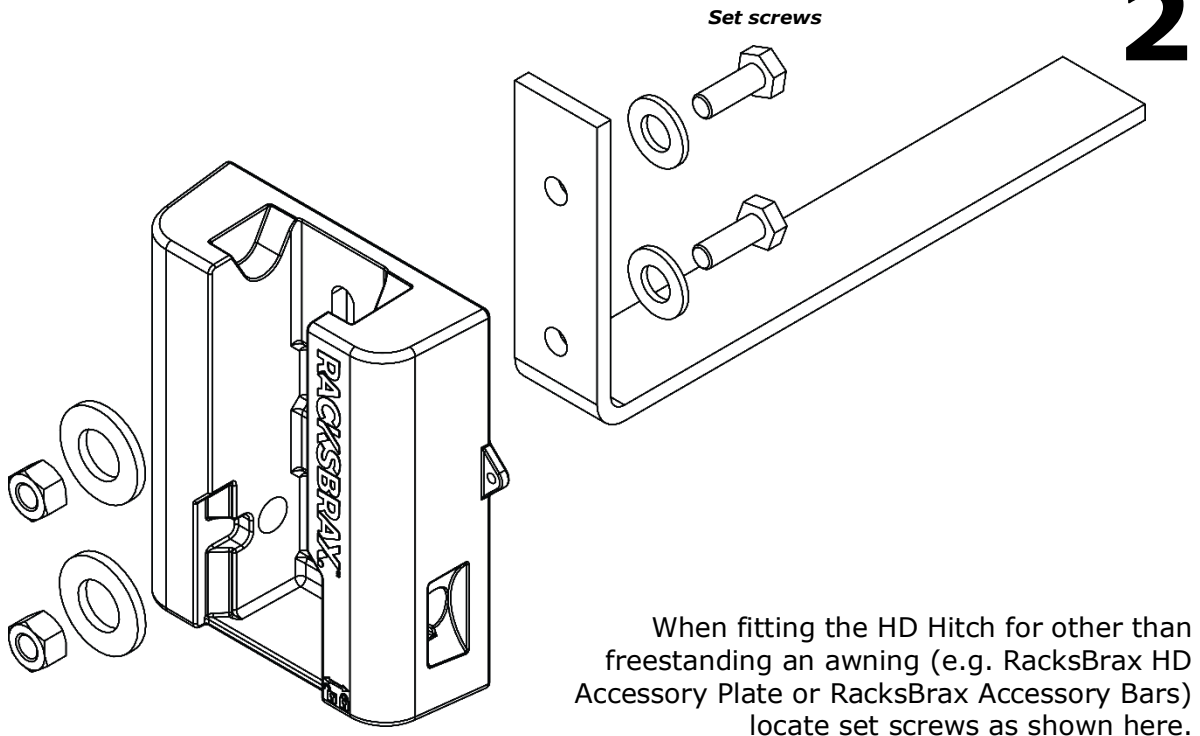

3

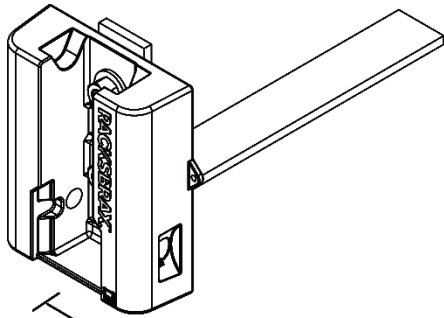

Bodies located vertically and parallel to each other.

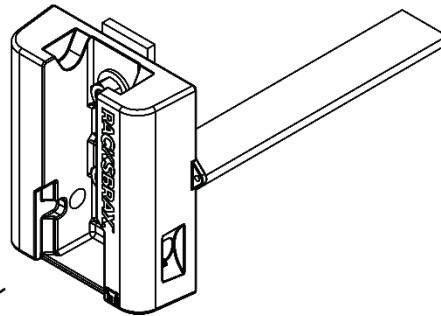
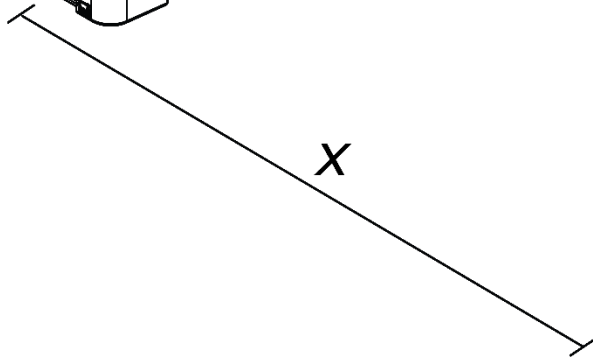

4

Secure HD Hitch Holder to the accessory using M6 (20mm) or M8 (25mm) set screws supplied.

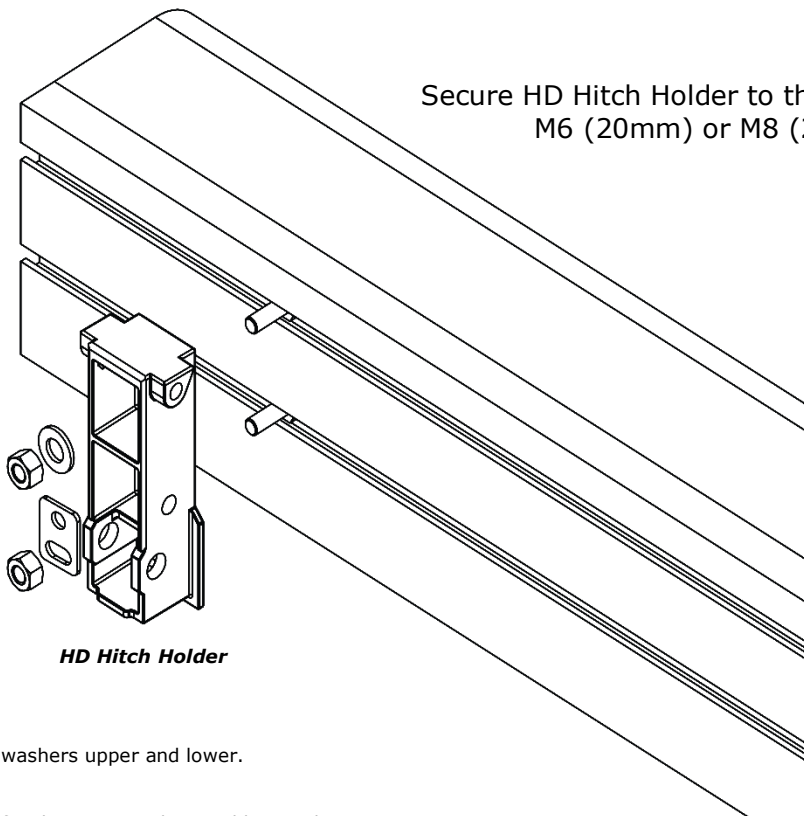

HD Hitch Holder

NOTE:

For M6 use

M6 (18mm) washers upper and lower.

For M8 use

M8 (22mm) for the upper and M8 Holder Washer (2 x 32 x 22.5mm) for the lower.

5

Ensure the HD Hitch Holders are the same distance apart (**x**) as the HD Bodies.

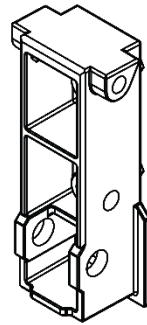
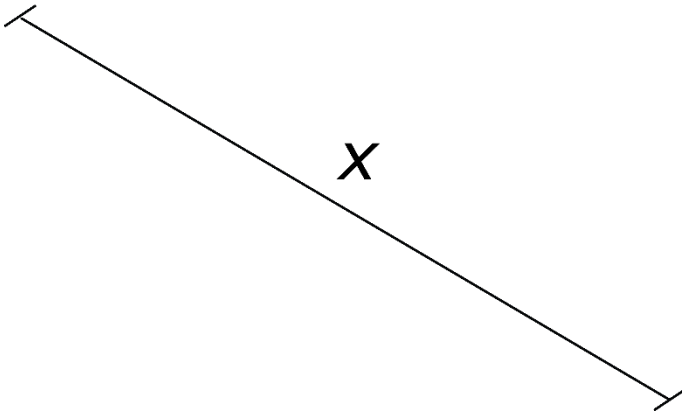
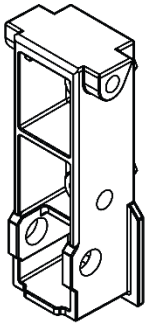

6

Load accessory onto HD Hitch Body.

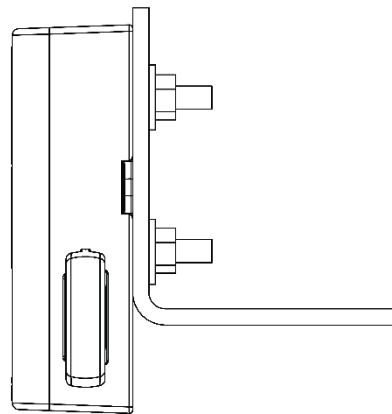
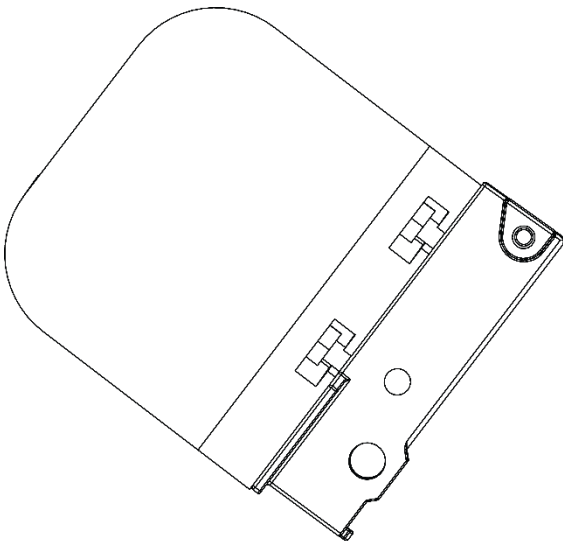

7

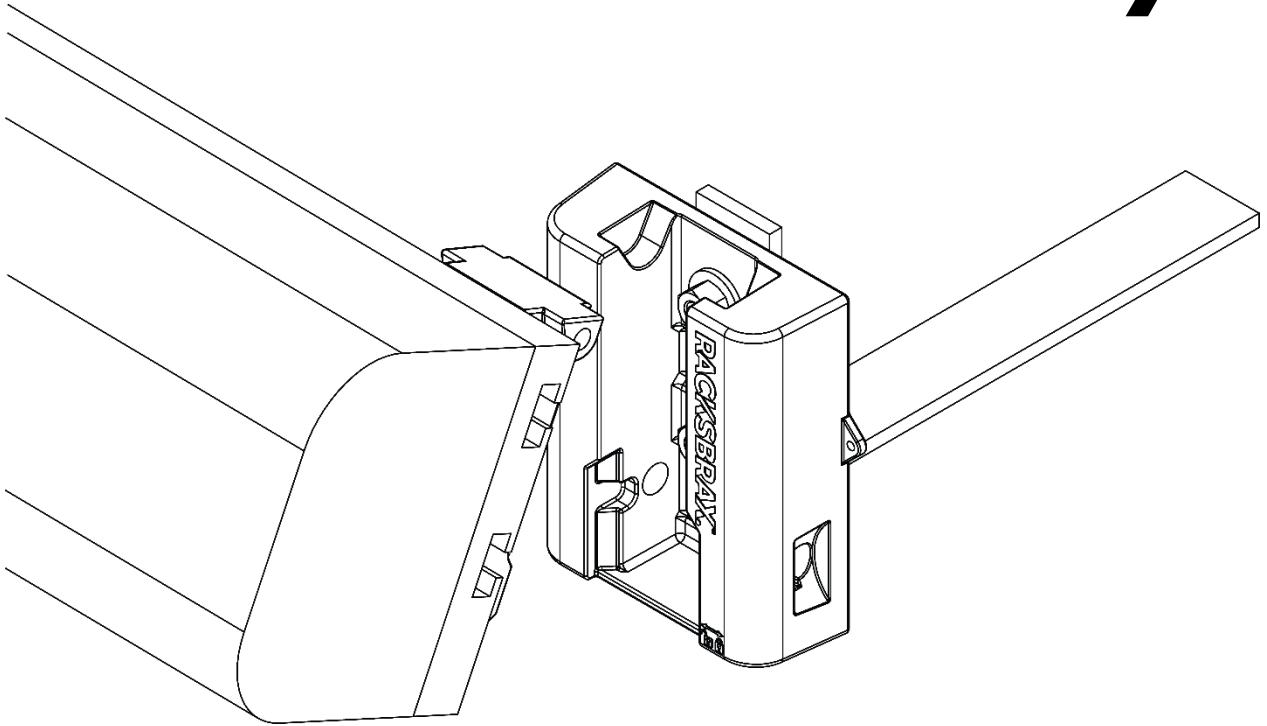

8

Fit Lanyard to the Body and Pin and insert Pin.

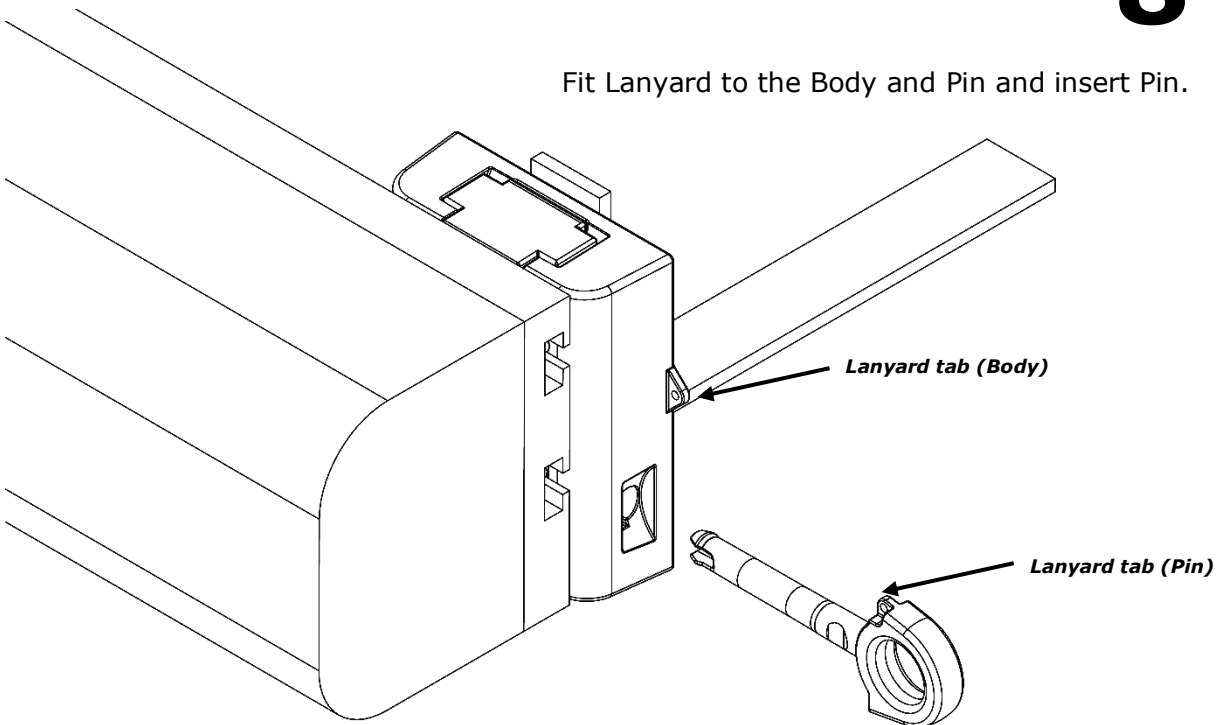

9

Lock in-built barrel lock to secure accessory.

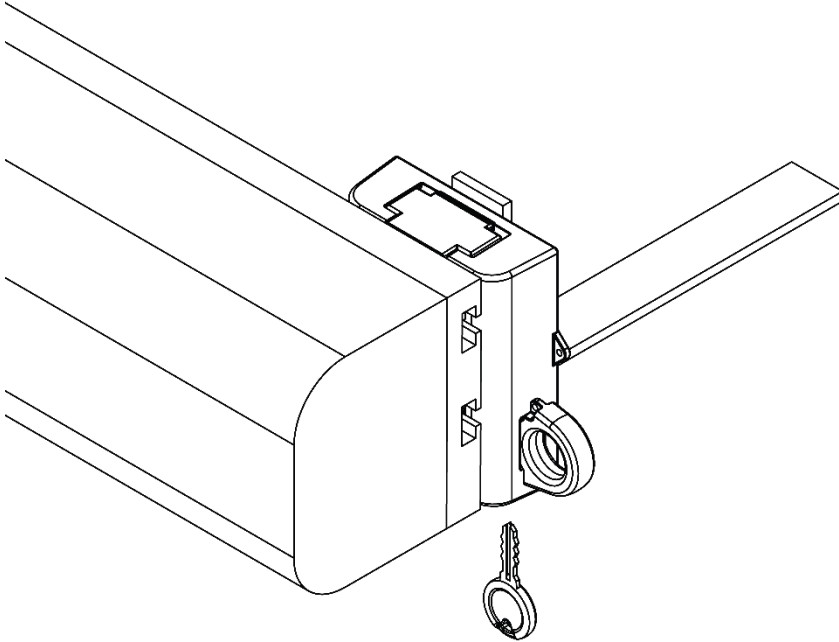

Note, if Key does not turn, the Pin is not fully inserted.

10

Prop Cleat location for use with pull-out awnings. Use M6 (25mm) or M8 (25mm) set screws supplied.

See pages 12 to 13 for freestanding instructions.

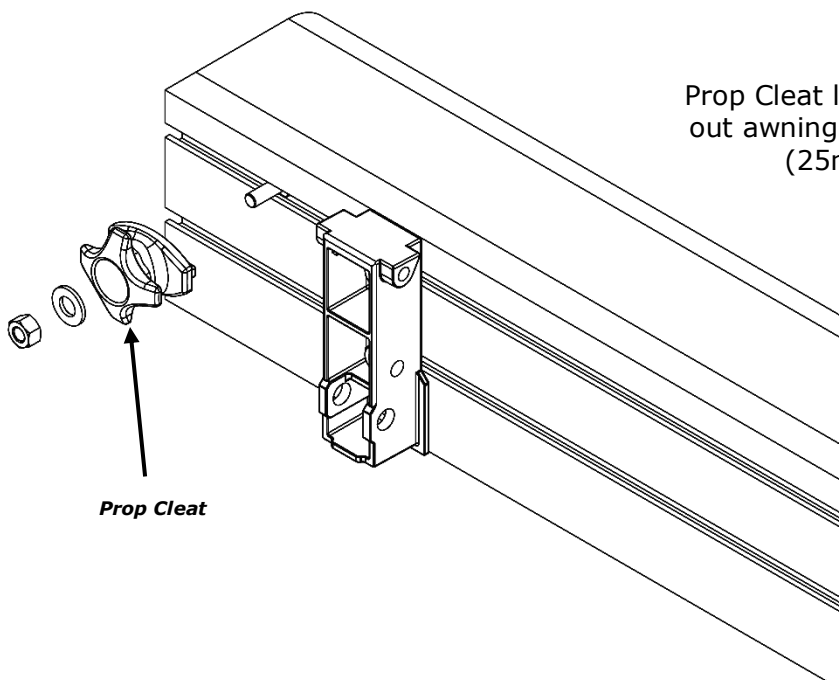

Prop Cleat

Prop Cleat and HD Hitch Holder fitted.

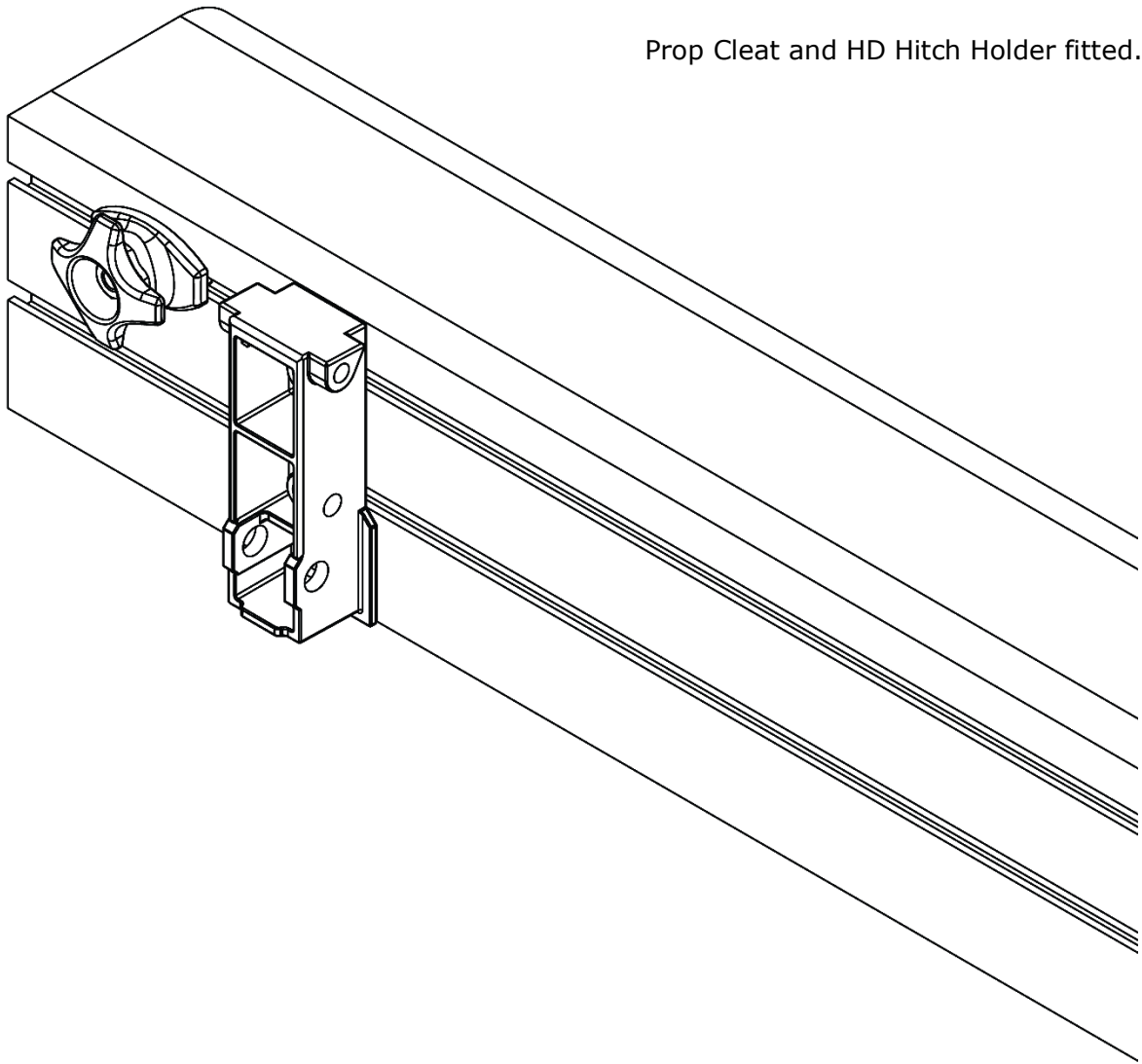

RACKSBRAX.

HOW TO SET A PULL-OUT AWNING FREESTANDING USING RACKSBRAX HD HITCH

1

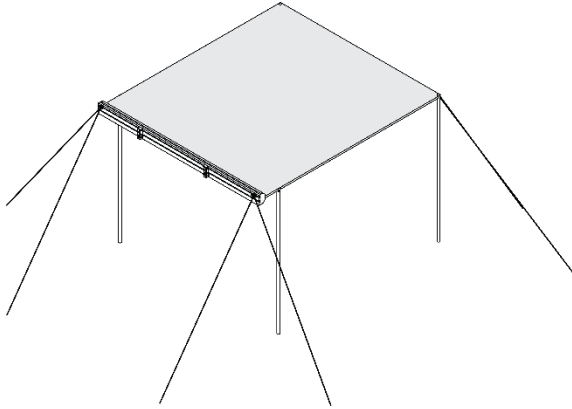

Freestanding pull-out awning.

2

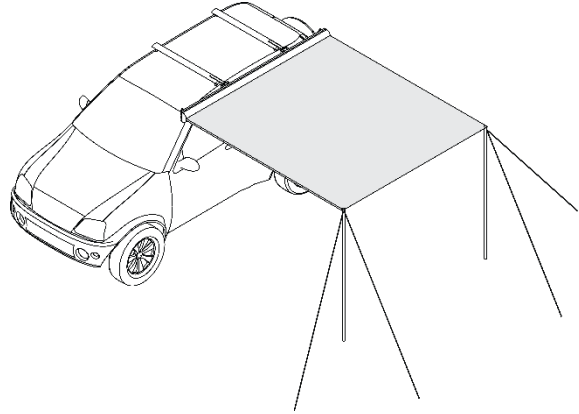

Set up your pull-out awning as normal but with a **pair** of guy ropes on each of the outer 2 corners.

3

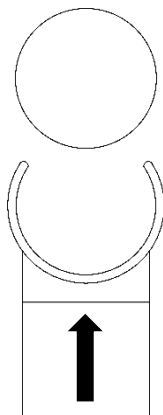

Attach C-clip poles to each horizontal "rafter" bar on the awning, then slide them up towards the vehicle adjusting them for length.

4

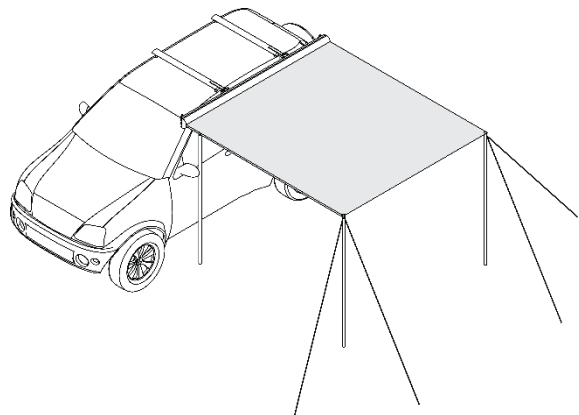

Place each C-clip tent pole close to your vehicle. Keep them approx. 100mm (4") away from the vehicle (*C-clip poles not included*).

RACKSBRAX.

5

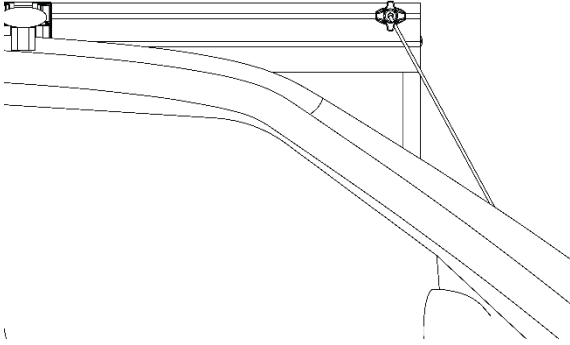

Attach a **pair** of guy ropes to the Prop Cleats at each end of the awning and peg one leg of each **pair** of guys ropes parallel to the vehicle (one to the front and one to the back of the vehicle).

6

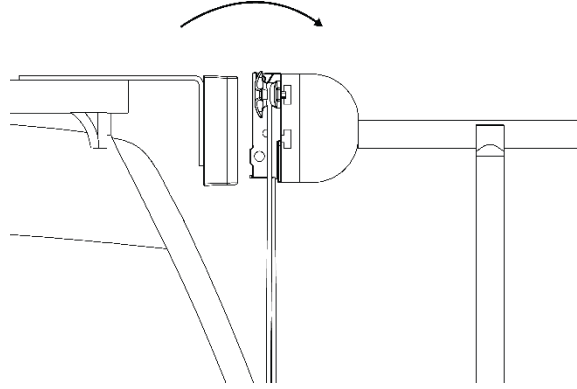

Assistant to un-hitch awning from vehicle and rest weight on C-clip tent poles.

7

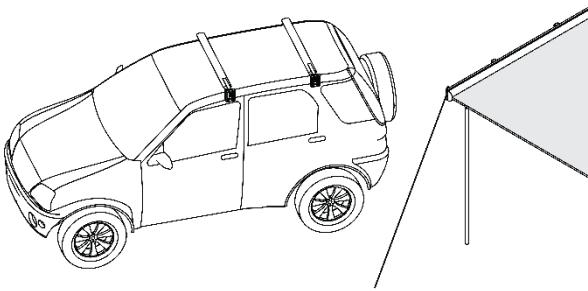

Assistant to hold awning while driver moves the vehicle. Assistant to ensure the 2 pairs of outer guy ropes remain taut. **Assistant to keep feet well clear of vehicle tyres!**

8

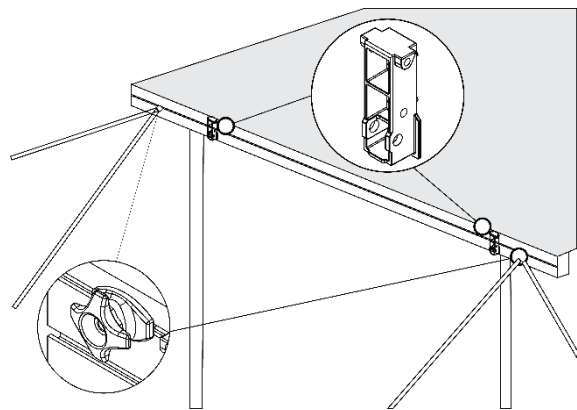

Driver returns to awning and pegs remaining 2 guy ropes, one from each Prop Cleat.

VOILA! YOUR AWNING IS NOW FREESTANDING WITH RACKSBRAX' HD HITCH!

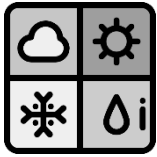

AWNINGS: WIND, RAIN AND SNOW

The HD Hitch/HD Awning Adaptor Plates mounting system is designed with a high load capacity relative to the weight of even the heaviest awnings. However, in the deployed state, loads from high winds, pooled rainwater, and accumulated snow can exceed the HD Hitch/HD Awning Adaptor Plate load capacity.

Always follow the awning manufacturer's recommendation with respect to awning use under conditions of wind, rain and snow. In addition, it is recommended that in windy conditions poles and guy ropes are always installed, and that during rain and snow events, that steps are taken to prevent excessive loading on the awning. For example, do not leave un-guyed awnings unattended if weather conditions may deteriorate.

Due to the high number of variables associated with wind direction, awning size and arrangement, local terrain, and other factors, it is not possible to provide meaningful wind speed recommendations.

THE 3 ENEMIES OF AWNINGS ARE: WIND, RAIN AND SNOW.

WIND: The wind loads on the awning mounting system relate to wind direction, wind strength, local terrain and awning area. In gusty conditions in particular, the loads on the awning are unpredictable, and may vary from upwards to downwards in a short space of time. It is recommended that in all but calm conditions, regardless of the awning manufacturer's instructions, that awnings should be restrained with poles and guy ropes to prevent damage to the mounting system.

RAIN: Most wing awnings come with a means to deflect runoff water from rain to avoid stretching the awning material (and causing other damage) when water collects in pools. Typically, this is accomplished with guy ropes set midway between the rafters and with poles at the rafters. To prevent potential overloading of the mounting system during heavy rain, drainage measures are recommended.

SNOW: The awning mounting system may be overloaded under snow loads. In snow conditions where heavy snow loads may develop, snow needs to be periodically cleared or the awning needs to be stowed.

Failure to adhere to any of these recommendations may void the RacksBrax Warranty.

**FAST ON!
FAST OFF!**

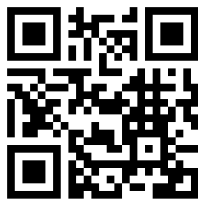

To learn more, scan the QR code or
visit ***racksbrax.com***